



Speed Queen Home Retail Dryer

ADEE9BSS543DN01

A proven performer

Speed Queen® dryers are designed, tested and built to deliver 25 years of commercial-grade performance in your home. Featuring customizable drying cycles, sophisticated airflow patterns, and advanced moisture sensing to deliver consistently superior results and efficiency. So you can reduce your dry times, eliminate unnecessary drying, lower your utility bills and protect your clothes.

Perfected drying

Through special drying cycles, a flawless Axial Airflow pattern and advanced moisture sensing, you can eliminate excessive drying and save money on your utility bill. If you want durability, innovation and perfectly dried laundry the first time, you need a Speed Queen dryer.

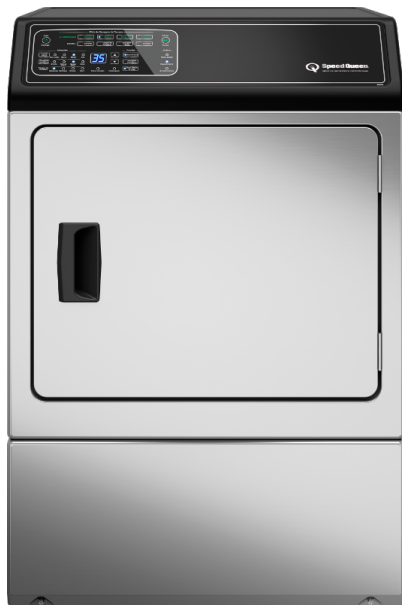

Specifications

Speed Queen Home Retail Dryer

Model	ADEE9BSS543DN01
General details	
Control	HEC
Control location	Front 45 degree
Actuation	None
Drum	
Capacity kg	10,5
Volume l	198
Power	
Motor power kW	0,25
Voltage	220/60/1
Cabinet	
Cylinder Finish	Stainless
Color	Stainless
Door type	Solid
Connections	
Electrical requirements	220/60/1
Transport data	
Net weight kg	57
Shipping weight kg	62
Dimensions HxWxD mm	1027 x 683 x 711
Packed dimensions HxWxD mm	1156 x 775 x 826
Packed volume m3	0,74

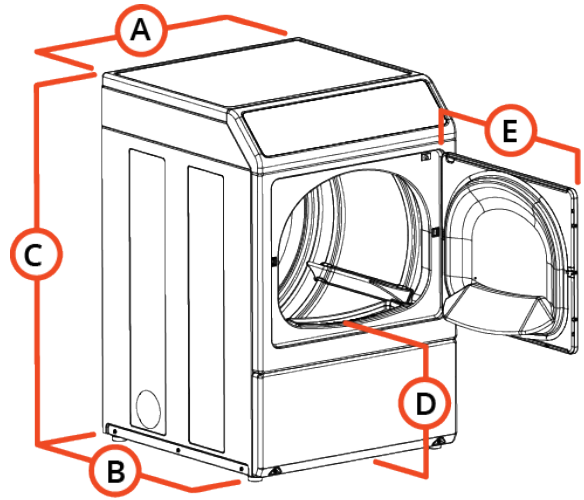

Dimensions

	mm
A	683
B	711
C	1027
D	392
E	597