



Speed Queen Home Retail Top Load Washer

AWNE9RSP305NW029

A proven performer

For more than a century Speed Queen has been focused on laundry, we know what it takes to deliver a machine with long-lasting strength, durability and performance like no other. And we put it all into our line of top load washers. Speed Queen® top load washers are built using premium metal parts where others use plastic. They're designed and manufactured to deliver 25 years of commercialgrade performance and superior wash results in your home. And they're pushed beyond their limits in our state-of-the-art test lab to ensure the kind of reliability you can only achieve with 100 years of ingenuity under your belt.

The professional wash

Speed Queen top load washers feature a one of a kind wash system that not only delivers the best wash available, but also takes care of clothes. Our auto fill system guarantees that every load uses enough water for an effective wash. The tub and agitator work together to create a gentle wash action that moves the maximum amount of water through the clothes providing the customer a premium wash and level of fabric care.

Control



Specifications

Speed Queen Home Retail Top Load Washer

Model	AWNE9RSP305NW29
General details	
Control	HEC
Control location	Rear
Actuation	None
Drum	
Capacity kg	10,5 Kg
Volume l	89,8
Drum speed	
G-factor	150
Extraction RPM	710
Power	
Motor power kW	0,37
Voltage	220-240/50/1
Cabinet	
Cylinder Finish	Stainless
Color	White
Door type	Solid
Connections	
Electrical requirements	220-240/50/1
Gas inlet connection mm	N/A
Water inlet	3/4"
Water Pressure kPa	1,4-8,3
Transport data	
Net weight kg	84
Shipping weight kg	89
Dimensions HxWxD mm	1092 x 711 x 651
Packed dimensions HxWxD mm	1143 x 762 x 711
Packed volume m3	0,62

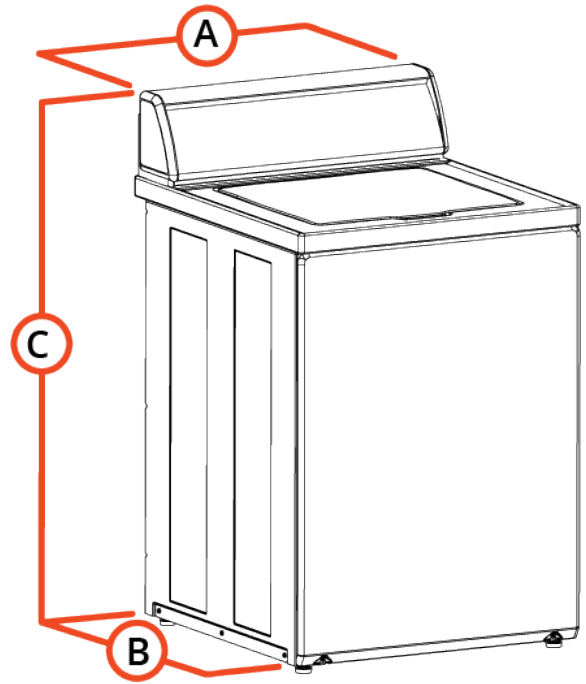

Dimensions

	mm
A	711
B	651
C	1092