



Speed Queen Homestyle Top Load Washer

LWNE52SP303NW26

A proven performer

For more than a century Speed Queen has been focused on laundry, we know what it takes to deliver a machine with long-lasting strength, durability and performance like no other.

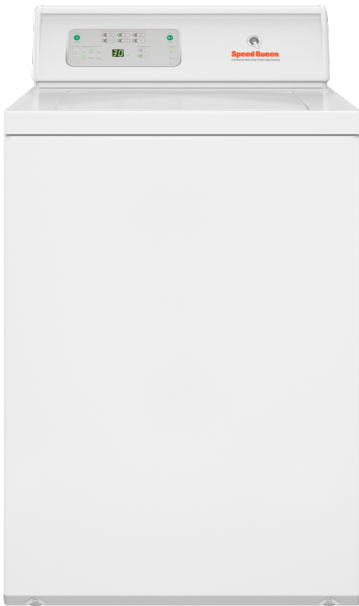

Built better to last longer

With a two-speed motor, the top load washer's 710 RPM maximum spin speed ranks among the highest in the industry, reducing drying times and handling high turnover volumes during peak periods. Our curved four-vane agitator delivers an industry-best 210° wash stroke, plus the new top panel wide-fan spray system rinses fabrics more evenly. It all adds up to unparalleled cleaning results. Speed Queen's exclusive stainless steel tub comes with a lifetime warranty, and actually becomes smoother with each use, so it won't pill, snag or fray clothes.

Commercial Grade Controls

Laundry is all we do, and we do it better than anyone else in the world. For decades, we've been designing, building and testing controls the same way we do our machines: for unmatched, longer-lasting performance. Tested to endure through virtually every event that typically causes malfunction, Speed Queen controls are durably designed to last in the harshest commercial environments — and last even longer in your home. We're so confident in our controls that we back our electronic models with an industry-best warranty on all parts and in-home labor.



Specifications

Speed Queen Homestyle Top Load Washer

Model		LWNE52SP303NW26
General details		
Control		HEC
Control location		Rear
Actuation		None
Drum		
Capacity kg		15
Volume l		90,3
Drum speed		
G-factor		150
Extraction RPM		710
Power		
Motor power kW		0,37
Voltage		220-240/50/1
Cabinet		
Cylinder Finish		Stainless
Color		White
Door type		Solid
Connections		
Electrical requirements		220-240/50/1
Gas inlet connection mm		N/A
Water inlet		3/4"
Water Pressure kPa		1,4-8,3
Transport data		
Net weight kg		84
Shipping weight kg		89
Dimensions HxWxD mm		1115 x 652 x 712
Packed dimensions HxWxD mm		1131 x 762 x 966
Packed volume m ³		0,62

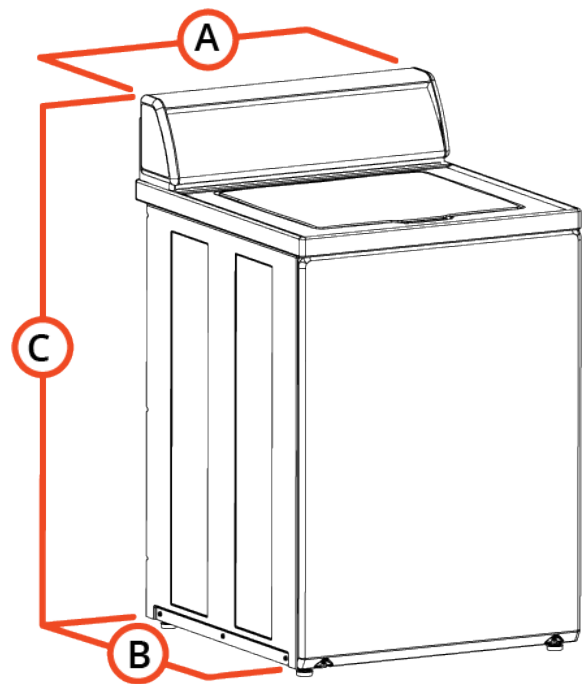

Dimensions

	mm
A	652
B	712
C	1115