



Speed Queen Home Retail Top Load Washer

AWNE9RSN305XW34

A proven performer

For more than a century Speed Queen has been focused on laundry, we know what it takes to deliver a machine with long-lasting strength, durability and performance like no other. And we put it all into our line of top load washers. Speed Queen® top load washers are built using premium metal parts where others use plastic. They're designed and manufactured to deliver 25 years of commercialgrade performance and superior wash results in your home. And they're pushed beyond their limits in our state-of-the-art test lab to ensure the kind of reliability you can only achieve with 100 years of ingenuity under your belt.

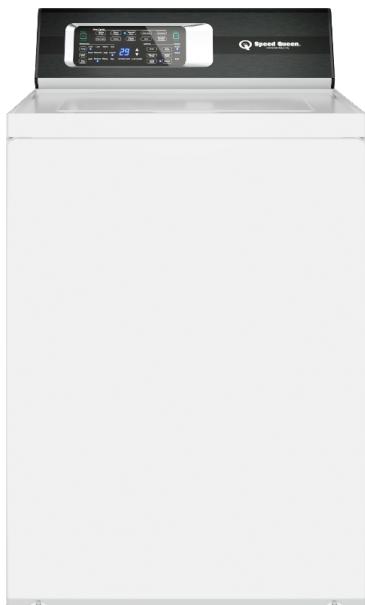

The professional wash

Speed Queen top load washers feature a one of a kind wash system that not only delivers the best wash available, but also takes care of clothes. Our auto fill system guarantees that every load uses enough water for an effective wash. The tub and agitator work together to create a gentle wash action that moves the maximum amount of water through the clothes providing the customer a premium wash and level of fabric care.

Commercial grade controls

Laundry is all we do, and we do it better than anyone else in the world. For decades, we've been designing, building and testing controls the same way we do our machines: for unmatched, longer-lasting performance. Tested to endure through virtually every event that typically causes malfunction, our controls are durably designed to last in the harshest commercial environments — and last even longer in your home. We're so confident in our controls



Specifications

Speed Queen Home Retail Top Load Washer

Model		AWNE9RSN305XW34
General details		
Control		HEC
Control location		Rear
Actuation		None
Drum		
Capacity kg		10,5
Volume l		90,3
Drum speed		
G-factor		200
Extraction RPM		820
Power		
Motor power kW		0,75
Voltage		240/50/1
Cabinet		
Cylinder Finish		Stainless
Color		White
Door type		Solid
Connections		
Electrical requirements		240/50/1
Water inlet		3/4"
Water Pressure kPa		1,4-8,3
Transport data		
Net weight kg		84
Shipping weight kg		89
Dimensions HxWxD mm		1092 x 711 x 651
Packed dimensions HxWxD mm		1143 x 762 x 711
Packed volume m3		0,62

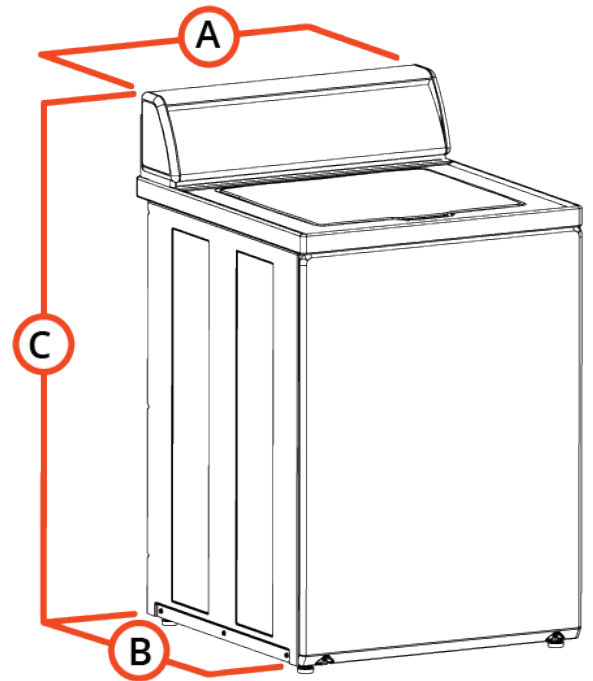

Dimensions

mm	
A	711
B	651
C	1092