



Speed Queen Home Retail Stack Washer and Dryer

ATEE9ASP565XW01

A proven performer

From the mechanically rolled brushed finish on the hood to the 1 million button pushes during testing, you know the outside is as solid and reliable as the inside. Our electronic controls are the most durable on the market. In fact, the controls manufactured for home use are the same controls you'll find in laundromats, hotels, and other commercial applications.



Proven performance - Half the space

When floor space is at a premium, Speed Queen stacked washer/dryers offer the perfect solution. This convenient design allows double the capacity in the space of one machine while sacrificing nothing in performance and wash/dry quality. Designed for ultimate user convenience, these two-in-one space savers also conveniently locate controls for both washer and dryer in the middle of the machine for easy access and operation.

Commercial grade controls

Laundry is all we do, and we do it better than anyone else in the world. For decades, we've been designing, building and testing controls the same way we do our machines: for unmatched, longer-lasting performance. Tested to endure through virtually every event that typically causes malfunction, our controls are durably designed to last in the harshest commercial environments — and last even longer in your home. We're so confident in our controls that we back our electronic models with an industry-best warranty on all parts and in-home labor.

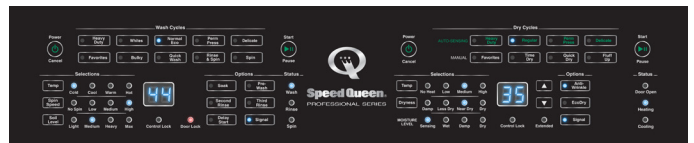

Specifications

Speed Queen Home Retail Stack Washer and Dryer

Model	ATEE9ASP565XW01	
General details		
Control	HEC	
Control location	Front 10 degree	
Actuation	None	
Drum		
Capacity kg	#VALEUR!	
Volume l	W-96,8/D-198	
Drum speed		
G-factor	440	
Extraction RPM	1200	
Power		
Motor power kW	W-0,67/D-0,25	
Voltage	#VALEUR!	
Cabinet		
Cylinder Finish	Stainless / Stainless	
Color	Stainless	
Door type	W-Window/D-Window	
Connections		
Electrical requirements	#VALEUR!	
Gas inlet connection mm	N/A	
Water inlet	3/4"	
Water Pressure kPa	1,4-8,3	
Transport data		
Net weight kg	175	
Shipping weight kg	189	
Dimensions HxWxD mm	1986 x 683 x 711	
Packed dimensions HxWxD mm	2032 x 762 x 864	
Packed volume m3	1,34	

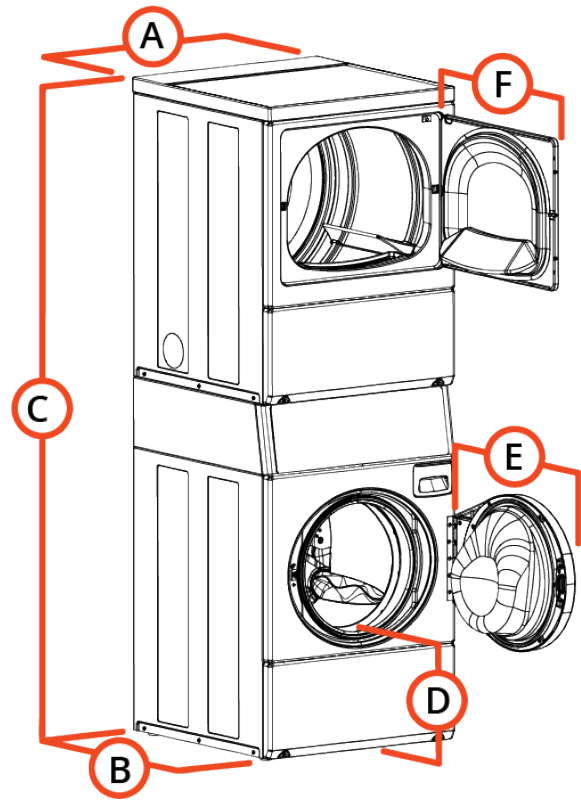

Dimensions

	mm
A	683
B	711
C	1986
D	371
E	610
F	597