



Speed Queen Home Retail Dryer

ADEE9BGS433XN34

A proven performer

Speed Queen® dryers are designed, tested and built to deliver 25 years of commercial-grade performance in your home. Featuring customizable drying cycles, sophisticated airflow patterns, and advanced moisture sensing to deliver consistently superior results and efficiency. So you can reduce your dry times, eliminate unnecessary drying, lower your utility bills and protect your clothes.



Perfected drying

Through special drying cycles, a flawless Axial Airflow pattern and advanced moisture sensing, you can eliminate excessive drying and save money on your utility bill. If you want durability, innovation and perfectly dried laundry the first time, you need a Speed Queen dryer.

Commercial Grade Controls

Laundry is all we do, and we do it better than anyone else in the world. For decades, we've been designing, building and testing controls the same way we do our machines: for unmatched, longer-lasting performance. Tested to endure through virtually every event that typically causes malfunction, Speed Queen controls are durably designed to last in the harshest commercial environments — and last even longer in your home. We're so confident in our controls that we back our electronic models with an industry-best warranty on all parts and in-home labor.



Specifications

Speed Queen Home Retail Dryer

Model	ADEE9BGS433XN34
General details	
Control	HEC
Control location	Front 45 degree
Actuation	None
Drum	
Capacity kg	10,5
Volume l	198
Power	
Motor power kW	0,25
Voltage	240/50/1
Cabinet	
Cylinder Finish	Galvanised
Color	Stainless
Door type	Solid
Connections	
Electrical requirements	240/50/1
Transport data	
Net weight kg	57
Shipping weight kg	62
Dimensions HxWxD mm	1027 x 683 x 711
Packed dimensions HxWxD mm	1156 x 775 x 826
Packed volume m3	0,74

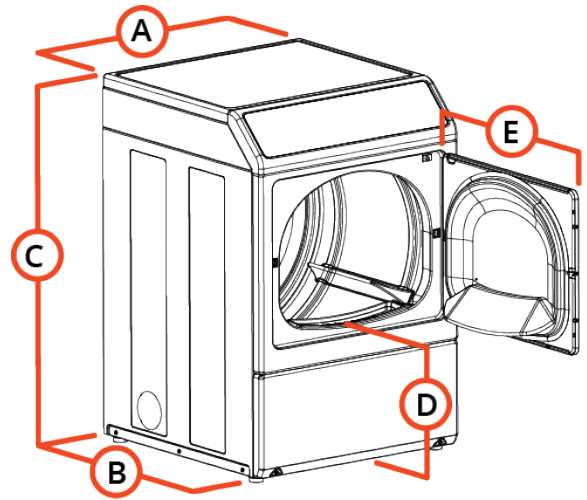

Dimensions

	mm
A	683
B	711
C	1027
D	392
E	597